

**IMPORTANT - READ CAREFULLY  
- RETAIN FOR FUTURE REFERENCE**

**WARNING :**

- The top surface of mattress must not be above the line marked on the frame. ( Max. high 177mm)  
The size of mattress should be : 920 x 1900mm
- Do not allow children under 6 years old to use the upper bunk.
- Be aware of the danger of young children (under 6) falling from the upper bunk.
- Bed should not be used if any structural part is broken or missing.
- Children can strangle in items such as ropes, string, cords, harnesses and belts attached to or hung on a bunk bed / high bed
- Children can become trapped between the bed and the wall. To avoid risk of serious injury the distance between the top safety barrier and the wall shall not exceed 75mm or shall be more than 230mm.
- Always ensure that the guardrails, ladder and other components are maintained in the proper position and are free from damage, and all the fixing screws are tight.
- Always use the ladder for entering and leaving the upper bunk.
- Do not allow horseplay on or under the bed and prohibit jumping on the bed.
- Use a nightlight as an added safety precaution for persons using the upper bunk.
- Use guardrails on both long sides of the upper bunk.

ITEM NO : JY-45080

# ASSEMBLY INSTRUCTIONS

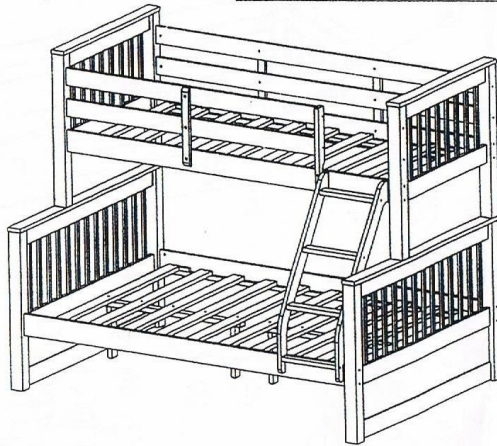

















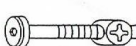



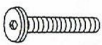

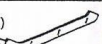



## ASSEMBLY TIPS

1. Remove hardware from box and sort by size.
2. Please check to see that all hardware and parts are present prior start of assembly.
3. Please follow attached instructions in the same sequence as numbered to assure fast and easy assembly.

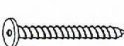

## Warning !

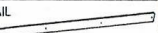
1. Don't attempt to repair or modify parts that are broken or defective. Please contact the store immediately.
2. This product is for home use only and not intended for commercial establishments.

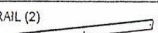
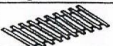
ITEM	Component List	QTY	ITEM	Component List	QTY	ITEM	Hardware List	QTY	ITEM	Hardware List	QTY
A	UPPER LEFT HEAD BOARD 	1	K	SMALL VERTICAL GUARD RAIL (1) 	3	1	HEXAGON BOLTS (Ø6x110 mm) 	22	7	SCREW (Ø4x30 mm) 	50
B	UPPER RIGHT HEAD BOARD 	1	L	SMALL VERTICAL GUARD RAIL (2) 	1	2	HEXAGON BOLTS (Ø6x70 mm) 	2	8	WOOD SCREW (Ø10x40 mm) 	38
C	LOWER LEFT HEAD BOARD 	1	M	LADDER POST (LEFT) 	1	3	HEXAGON BOLTS (Ø6x45 mm) 	7	9	STANDER (Ø6x25 mm) 	4
D	LOWER RIGHT HEAD BOARD 	1	N	LADDER POST (RIGHT) 	1	4	HEXAGON BOLTS (Ø6x35 mm) 	9	10	LOCATING PIN (Ø10x125mm) 	4
E	UPPER FRONT SIDE RAIL (5 hole) 	1	O	LADDER STAIR (1) 	3	5	CAP NUT (Ø6x15 mm) 	11	11	ALLEN KEY (K4) 	2
F	UPPER BACK SIDE RAIL (2 hole) 	1	P	LADDER STAIR (2) 	1	6	ALLEN HEAD SCREW (Ø7x50 mm) 	12			
G	UNDER FRONT SIDE RAIL (3 hole) 	1	Q	SUPPORT BAR 	2						
H	UNDER BACK SIDE RAIL (No hole) 	1	R	SUPPORT LEG 	4						
I	BACK GUARD RAIL 	2	S	SLAT ROLL (SHORT) 	1						
J	FRONT GUARD RAIL (2) 	2	T	SLAT ROLL (LONG) 	1						

STEP 1

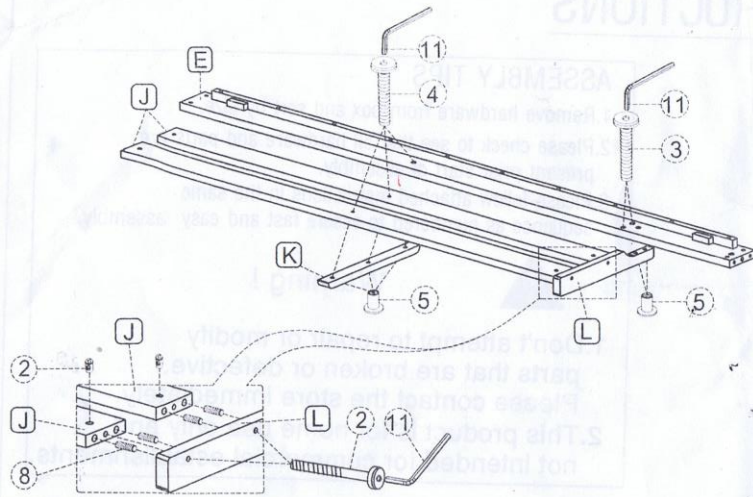

STEP 3

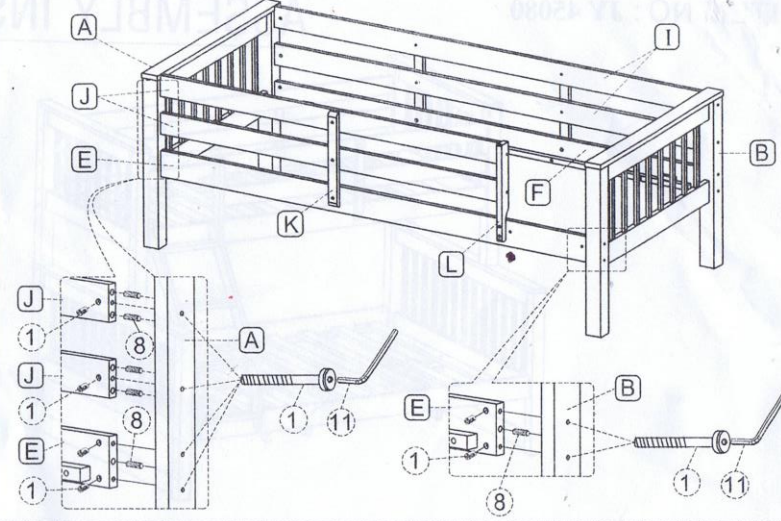

STEP 2

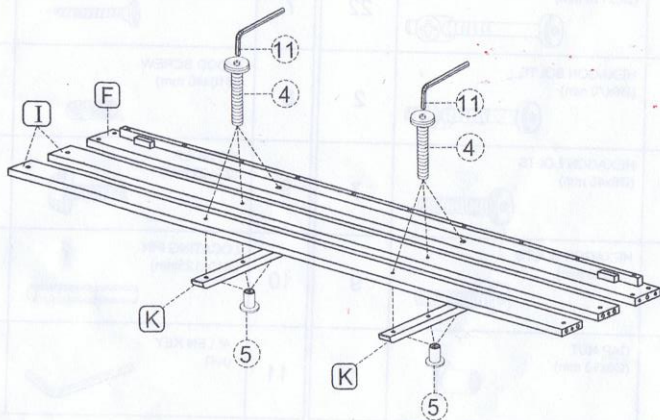

STEP 4

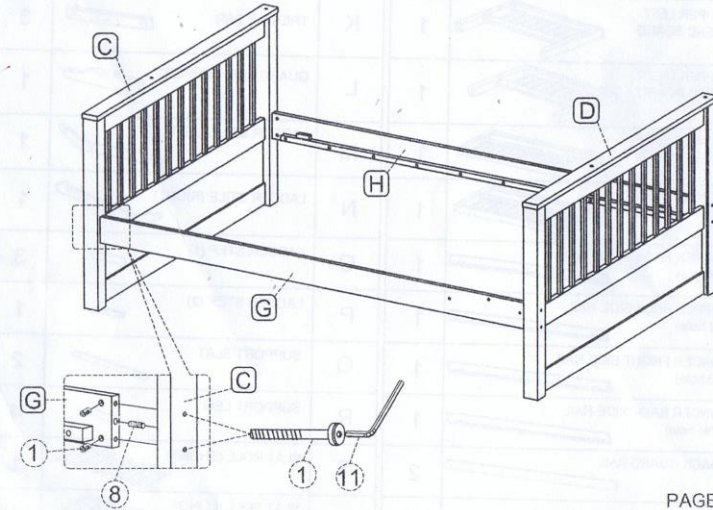

STEP 5

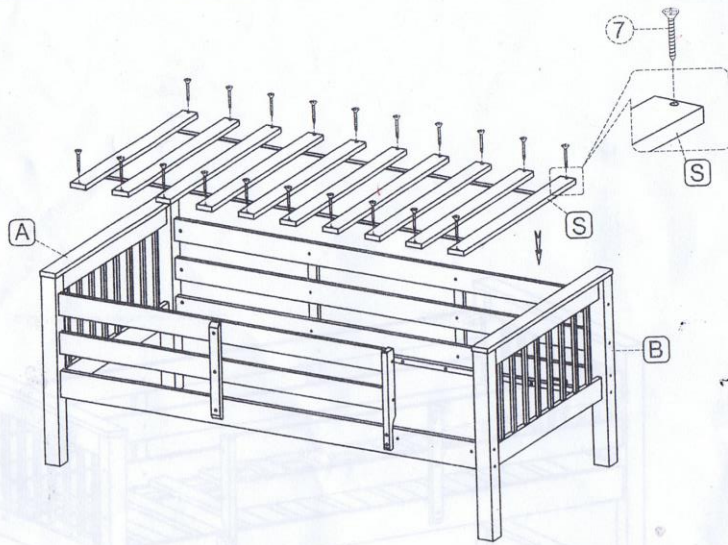

STEP 7

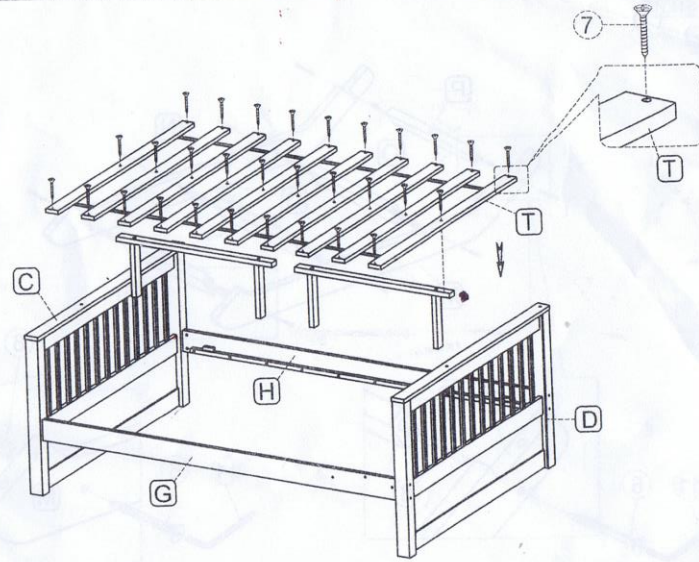

STEP 6

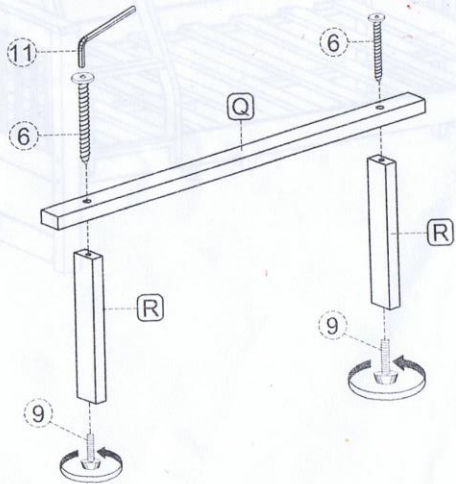

STEP 8

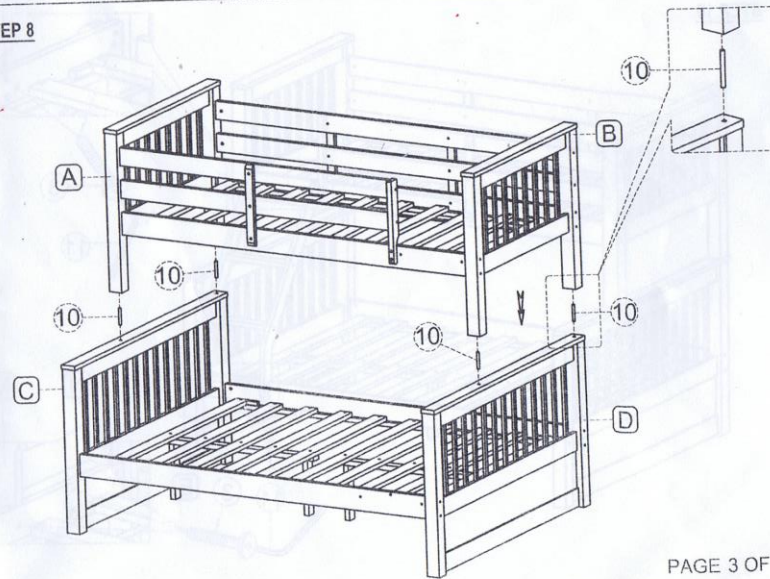

STEP 9

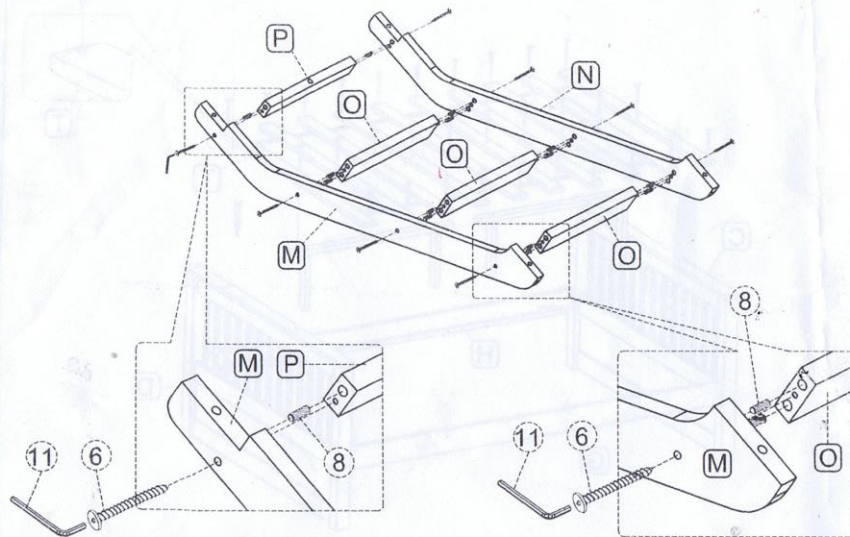

STEP 10

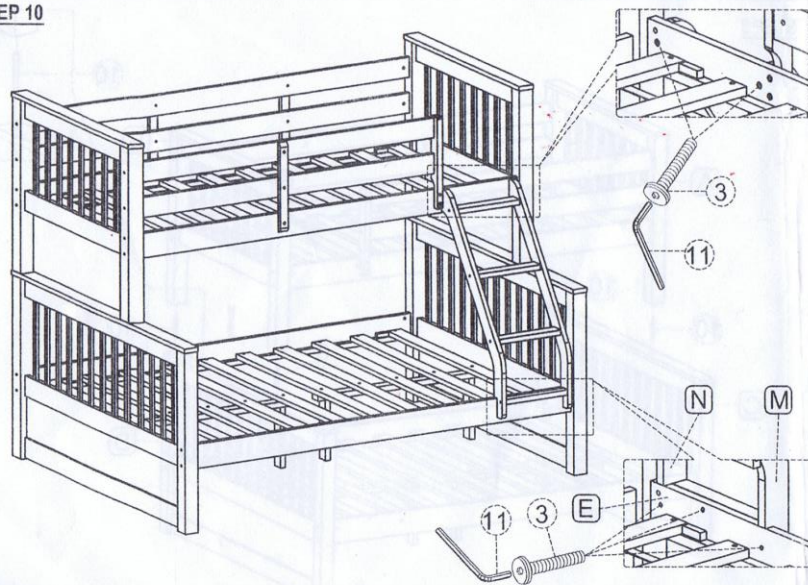

FINISH

